

FL180 COVER

SEAL

FL180 FRAME

18" diameter flat sealed composite cover and frame.

For reference purposes only. This drawing is not a specification. Order against product code only. To enable continuous improvement of our products, the designs and specifications are subject to change without notice.

FIBRELITE 
PART OF OPW A  DOVER COMPANY

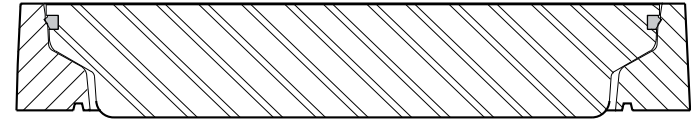
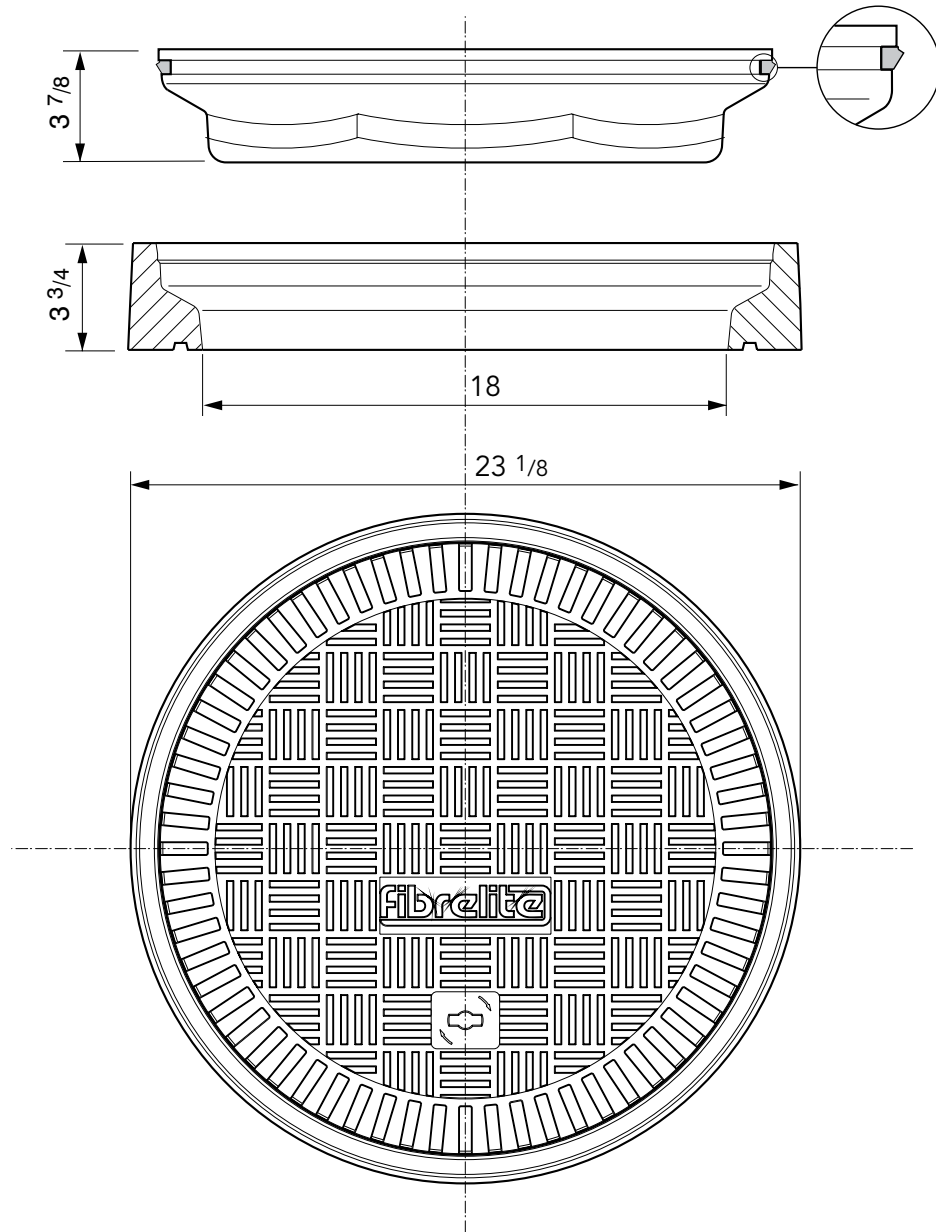

Load Rating	Cover Weight	Frame Weight
LD	19 lbs	11 lbs
SD	22 lbs	11 lbs
HD	--	11 lbs

18" diameter flat sealed composite cover and frame.

For reference purposes only. This drawing is not a specification. Order against product code only. To enable continuous improvement of our products, the designs and specifications are subject to change without notice.

FIBRELITE 
PART OF OPW A DOVER COMPANY

CONCRETE

VERY IMPORTANT

OUTER EDGE "A" OF FRAME SET 1/4 - 1/2 ABOVE GENERAL GRADE AREA WITH CONCRETE RAMPED AWAY OVER 12"

VERY IMPORTANT

The underside of the frame must be adequately supported by concrete.

Expansion joint filled with petrol resistant mastic.

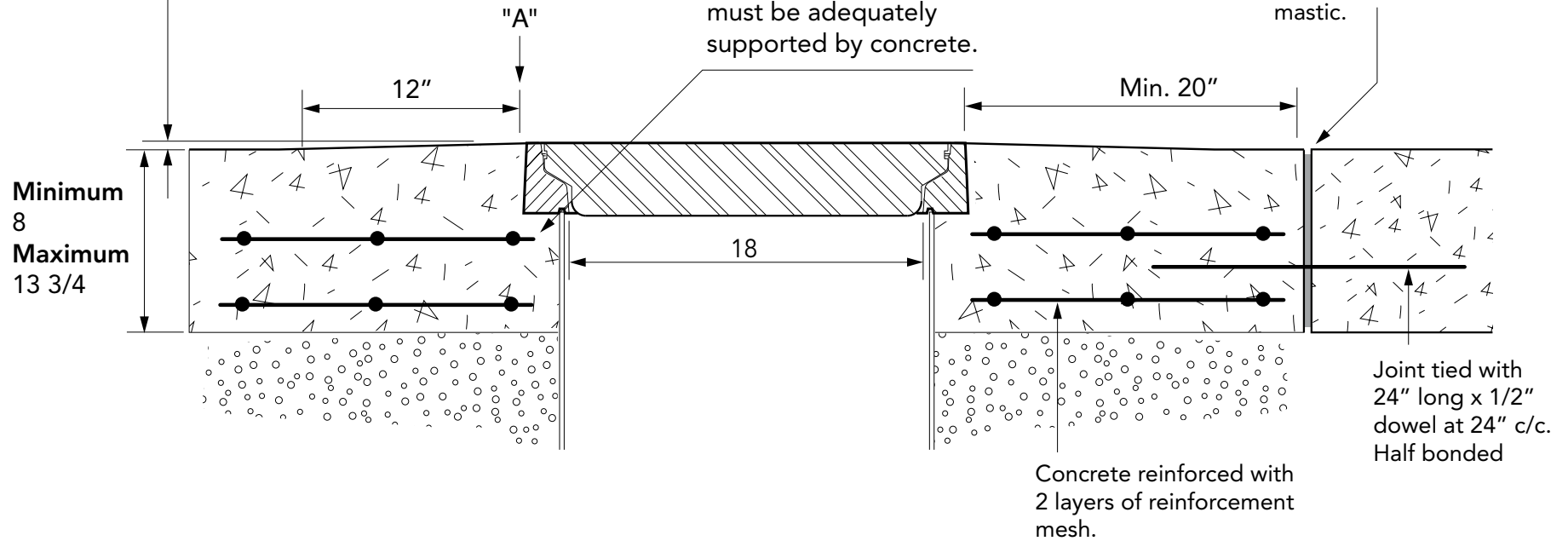

BLACKTOP

THICKNESS AS SPECIFIED

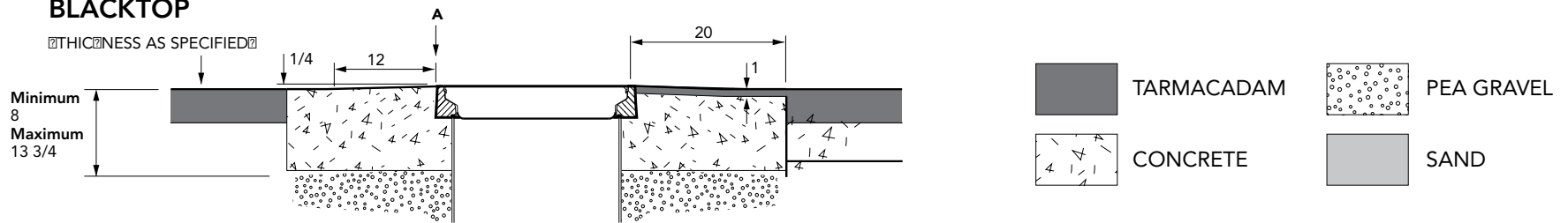

18" diameter flat sealed composite cover and frame.

For reference purposes only. This drawing is not a specification. Order against product code only. To enable continuous improvement of our products, the designs and specifications are subject to change without notice.

FIBRELITE 
PART OF OPW A DOW COMPANY